



SC SERIES • CAPACITY 1600

# Scaffold Casters

- Deep toothed gears for swivel lock and wheel simultaneously
- Integrated brake arm with fork legs
- Zinc plated finish

**Warning:**

DO NOT RIDE ROLLING TOWERS.

Check that caster is securely locked before climbing scaffolding.

Do not attempt to use if caster is faulty or has not been properly maintained.

SCHR50GB821075275RD



SCHR50GB821250400SQ

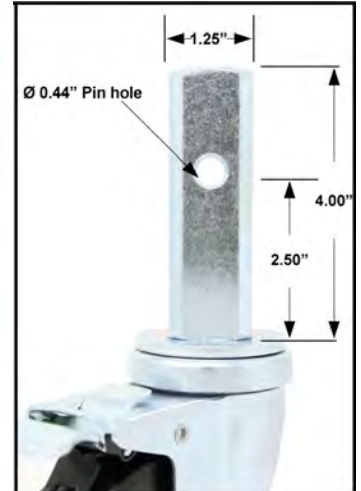

Wheel Dia.	Tread Width	Wheel Type	Load Capacity	Bearing Type	Part #	O.A.H.	Swivel Radius
5"	1-1/4"	Hard Rubber	250	Bushing	SCHR50GB821075275RD	6-1/4"	4-1/4"
					SCHR50GB821250400SQ		

SCRS80JB041384

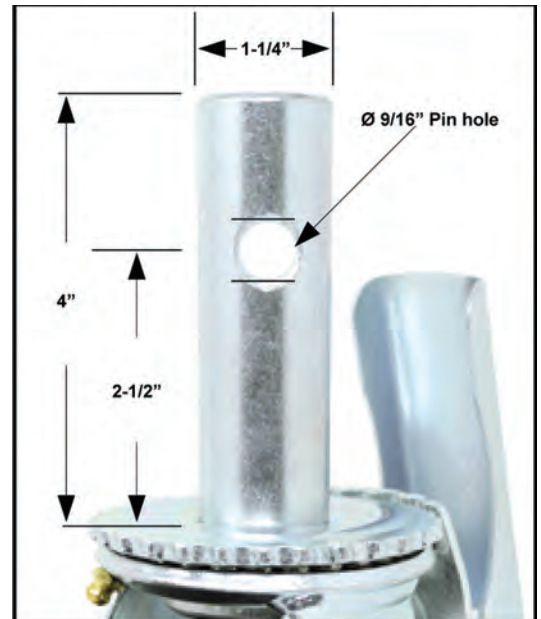

Wheel Dia.	Tread Width	Wheel Type	Load Capacity	Bearing Type	Part #	O.A.H.	Swivel Radius	Wheel Color
6"	2"	Mold on Rubber	440	Roller	SCRS60JB041254	7-5/16"	5"	
		Polyon™	440	Roller	SCPU60J+041254			G,V
		Poly-Pro™	440	Roller	SCPP60J+041254			D,I,K,M,U,W
8"	2"	Mold on Rubber	550	Roller	SCRS80JB041254	9	6-3/8	
		Polyon™	550	Roller	SCPU80J+041254			G,V
		Poly-Pro™	550	Roller	SCPP80J+041254			D,I,K,M,U,W



SCPP80JK041254

SCRS80LB241384

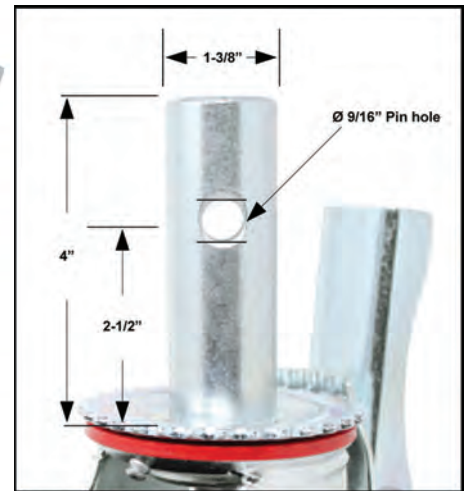

Wheel Dia.	Tread Width	Wheel Type	Load Capacity	Bearing Type	Part #	O.A.H.	Swivel Radius	Wheel Color
6"	2"	Mold on Rubber	440	Roller	SCRS60JB041384	7-5/16	5	
		Polyon™	440	Roller	SCPU60J+041384			G,V
		Poly-Pro™	440	Roller	SCPP60J+041384			D,I,K,M,U,W
8"	2"	Mold on Rubber	550	Roller	SCRS80JB041384	9-1/2	6	
		Polyon™	550	Roller	SCPU80J+041384			G,V
		Poly-Pro™	550	Roller	SCPP80J+041384			D,I,K,M,U,W

SCRA12QI241384

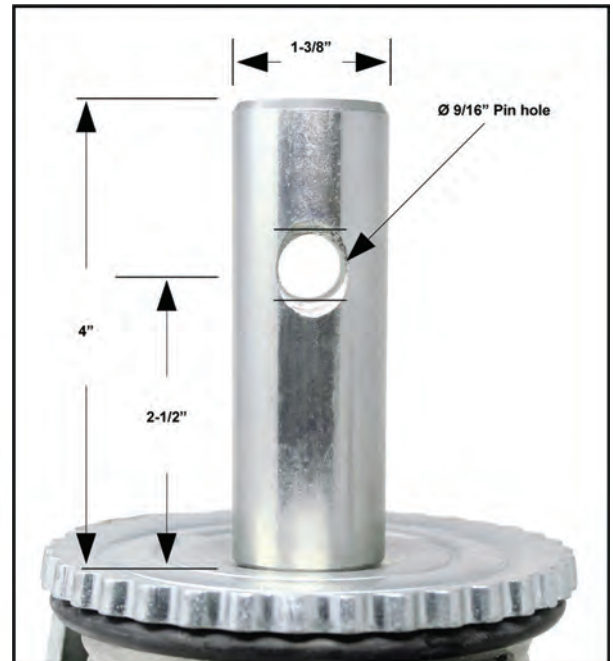

Wheel Dia.	Tread Width	Wheel Type	Load Capacity	Bearing Type	Part #	O.A.H.	Swivel Radius	Wheel Color
8"	3"	Mold on Rubber	850	Roller	SCRS80LB241384	10-1/4"	6-1/2"	
		Polyon™	1300		SCPU80L+241384			G,V
10"	3"	Rubber on aluminum	1000	Roller	SCRA10LI241384	12-1/4"	8"	
		Mold on Rubber			SCRS10LB241384			G,V
		Polyon™	1500		SCPU10L+241384			
12"	3"	Rubber on aluminum	1150	Roller	SCRA12LI241384	14-1/2"	9"	
		Mold on Rubber			SCRS12LB241384			G,V
		Polyon™	1600		SCPU12L+241384			

SC SERIES • CAPACITY 1600